



Hydraulic Presses

KP 70 • 100 • 150 • 200

154,000 to 440,000 lbs force

- cylinder stroke 19"
- stroke rate 0.08"/s

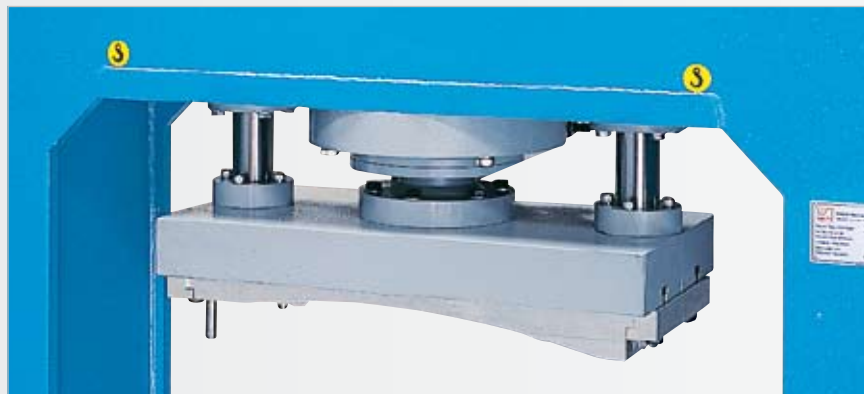

KP 70 • 100 • 150 • 200



KNUTH
KP 70 • 100 • 150 • 200

DESCRIPTION

Hydraulic Press for bending punching, press molding

- a powerful hydraulic cylinder and two circular guides ensure precise and uniform feed of the ram plate during press operations
- suitable for use as a tryout press
- ram plate and large work table with T-slots for tool clamping
- firmly bolted work table
- adjustable limit stop

Work Sample

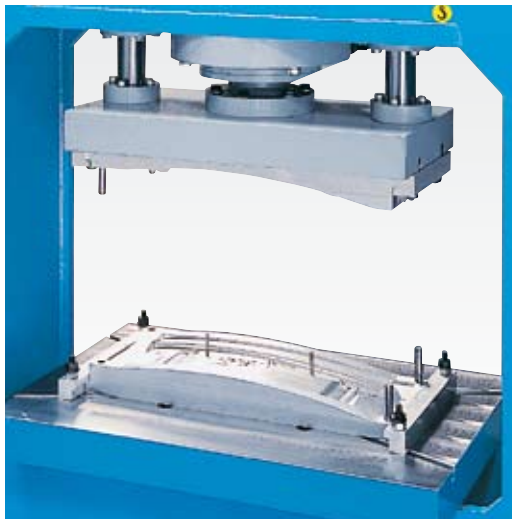

KP 70 shown



www.knuth-usa.com



SPECIFICATIONS

KP 70 • 100 • 150 • 200

Specifications	KP 70	KP 100	KP 150	KP 200
Working area				
force	154,000 lbs	220,000 lbs	330,000 lbs	440,000 lbs
stroke length	19"	19"	19"	19"
stroke rate	0.08"/s	0.08"/s	0.08"/s	0.08"/s
rapid feed	0.75"/s	0.87"/s	0.75"/s	0.75"/s
Drive Capacities				
motor rating	2 Hp	5.4 Hp	4,25 Hp	10.1 Hp
Dimensions/Weight				
weight	2,420 lbs	3,520 lbs	6,600 lbs	9,480 lbs
Part No.	131 560	131 565	131 570	131 575

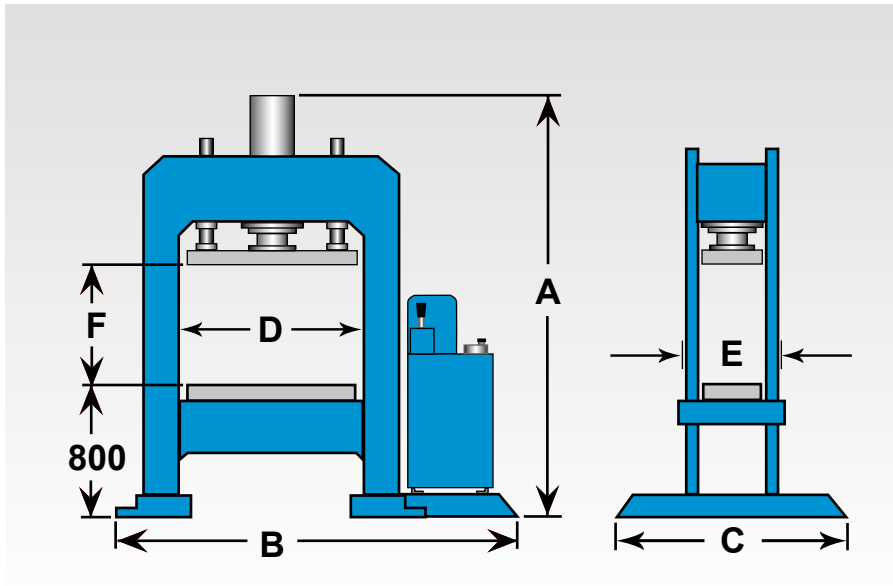

Model	KP 70	KP 100	KP 150	KP 200
A	89"	91"	102"	107"
B	67"	75"	91"	91"
C	28"	34"	40"	59"
D	35"	41"	49"	49"
E	19"	23"	27"	27"
F	19"	19"	19"	19"