



## Hydraulic Shop Presses

# KNWP

**66,000 lbs to 352,000 lbs  
tons force**

- horizontal piston adjustment included (except for KNWP 30M)
- ideal for repair and assembly work



**KNWP**

[www.knuth-usa.com](http://www.knuth-usa.com)

## Hydraulic Workshop Press with double-acting cylinder (except for KNWP 30M) easy handling

- truing of axles, supports, shafts, and much more
- removal and pressfitting bearings and bushings

all HM models with motorized hydraulic drive

- automatic ram return
- 2-step hydraulic unit supply voltage 220V, 3 ph, 60 Hz
- horizontal piston adjustment

DESCRIPTION



KNWP 30M shown



KNWP 60HM shown



KNWP 100HM shown



**SPECIFICATIONS**

Specifications	KNWP30M	KNWP60HM	KNWP100HM	KNWP160HM
force	66,000 lbs	132,000 lbs	220,000 lbs	352,000 lbs
motor rating	-	2 Hp	3 Hp	4 Hp
stroke rate (2 steps)	-	5.2" 22"	6.3" 22"	5.4" 22"
return speed	-	30 ipm	29 ipm	28 ipm
max. pressure	4500 psi	3400 psi	3850 psi	4100 psi
piston stroke	8.5"	15.75"	15.75"	15.75"
<b>Hydraulics</b>				
flow rate	-	.8 / 3.5 g/min	1.5 / 5 g/min	1.9 / 7.2 g/min
oil tank capacity	0,5 gal	5 gal	5 gal	5 gal
<b>dimensions</b>				
A	78"	80"	83"	87"
B	33"	45"	52"	63"
C	30"	35"	35"	43"
D	22"	30"	36"	43"
E	8"	10"	12"	14"
F	36"	59"	63"	75"
G	6"	6"	6"	6"
H	7"	7"	7"	8"
I	35"	30"	30"	30"
J	9"	20"	22"	24"
K	5"	8"	9"	13"
weight	510 lbs	1,510 lbs	2,110"	3,470 lbs
Part No.	131 740	131 760	131 762	131 764

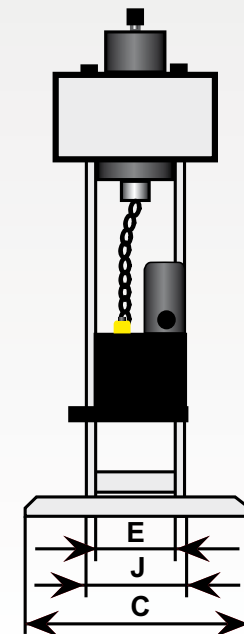
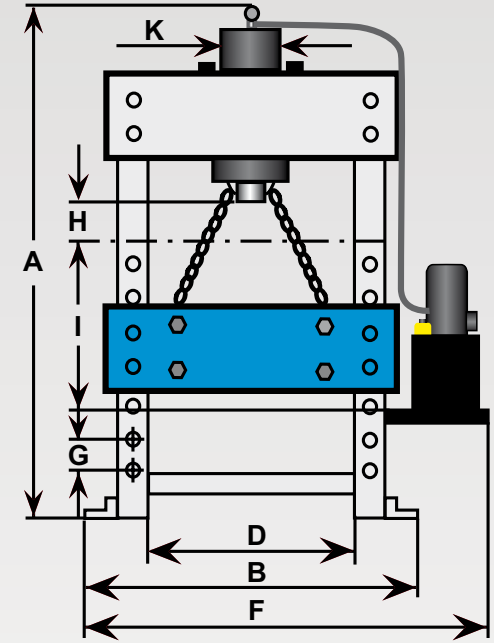

**KNWP**